



# Keep Calm and Make Music

Weekly Wonder  
Discovering the  
Musical Dimensions KS1



Hampshire  
County Council

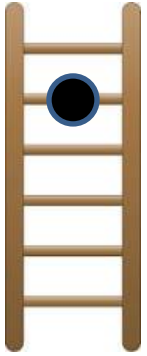

Pitch

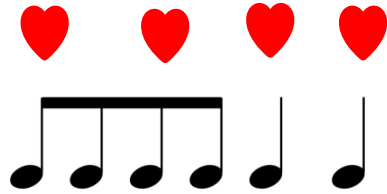

Duration



Dynamics

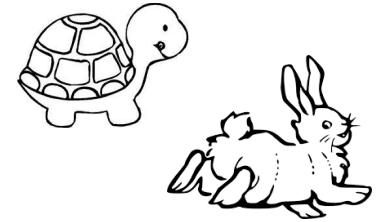

Tempo

# Discovering the Musical Dimensions

(there are seven altogether)

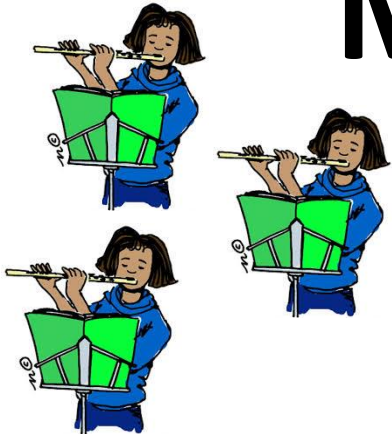

Texture

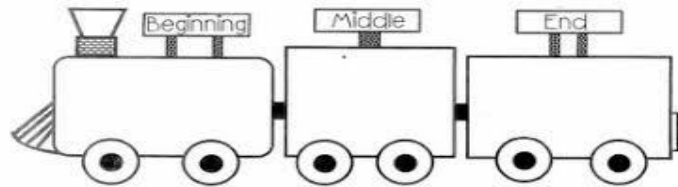

Structure

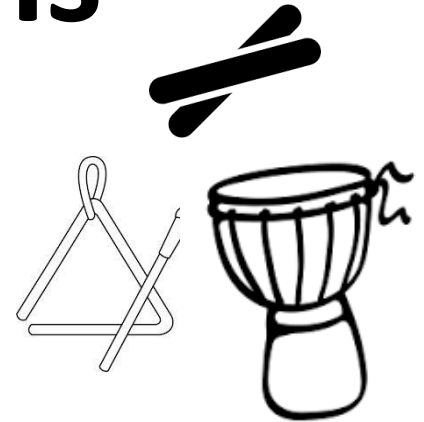

Timbre

# Contents – homepage

Click on the  to return to this page

There are seven musical dimensions – one for every day of the week!  
Which one will you discover today? Click on one and off you go

[Pitch](#) – what it means and fun pitch activities

[Duration](#) – what it means and fun duration activities

[Dynamics](#) – what it means and fun dynamic activities

[Tempo](#) – what it means and fun tempo activities

[Structure](#) – what it means and fun structure activities

[Texture](#) - what it means and fun texture activities

[Timbre](#) – what it means and fun timbre activities

[Quiz time](#)

Don't try and do them all in one go it could be a bit





# PITCH

is all about how high or low sounds are

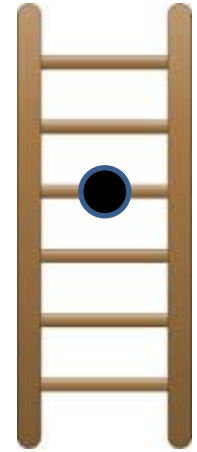

## Key words

High, middle and low

Higher and lower

## [Click here](#)

to find out about high, middle and low sounds and sing a fun song about those sounds

# Fun pitch activities

- Listen to the story of [Goldilocks and the three bears](#) and enjoy using low, middle and high voices for daddy, mummy and baby bear
- Join in with this fun [high and low game](#)
- Have fun moving to this version of [Teddy Bear's Picnic](#). Walk in time to the **low** sounding footsteps and wave your arms in the air every time you hear a **high** sound



# DURATION

is all about how long and short sounds are and beat and rhythm

## Key words

Long



Short



Steady beat 

Rhythm pattern xx xx x x

[Click here](#)

to find out about the steady beat

[Click here](#)

to find out about rhythm

# Fun duration activities

Listen to [Only time will tell](#) by Mike Oldfield

Tap along to the steady beat (beep) on your thighs

Can you move like a robot to this music?



Create a 4 item **beet** and **cherry** rhythm pattern to tap along to the music e.g.

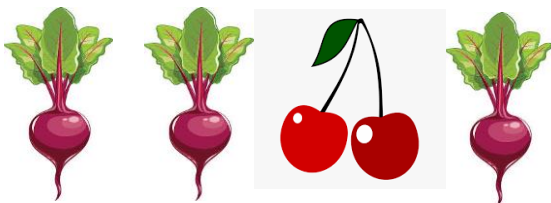

or

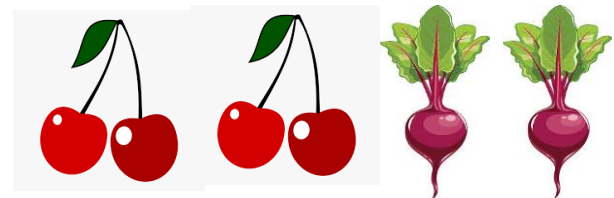



# DYNAMICS



is all about how loud or quiet sounds are

## Key words



Loud and quiet



Louder and quieter

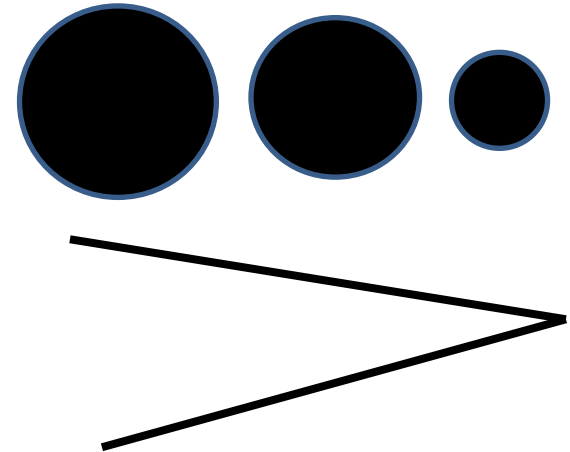
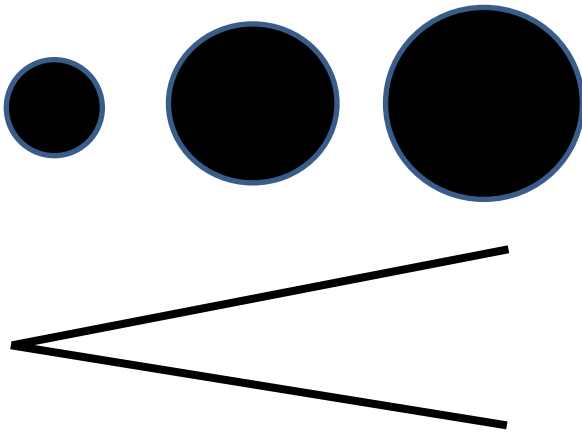

[Click here](#)

to find out about loud and quiet sounds

# Fun dynamic activities

Make someone jump  
Creep up quietly then shout



Listen the [March Past of the Kitchen Utensils](#)

Tiptoe around the room when the music is quiet

Clap loudly on the cymbal crash

Once you have got to know the music find something you can make a loud clashing sound with and join in with the cymbal



# TEMPO

is all about how fast and slow the music is

## Key words

Fast and slow

Faster and slower

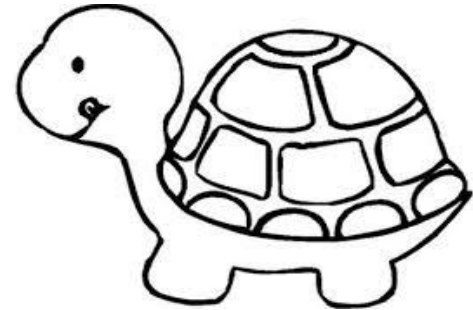

[Click here](#)

to find out about fast and slow sounds

Presto means fast and largo mean slow

# Fun tempo activities

Listen to [Slowly, slowly walks my grandad](#)

Enjoy walking like grandad, mother and the child singer

Join in with [Baby Shark](#)

How fast can you sing? Can you keep up?

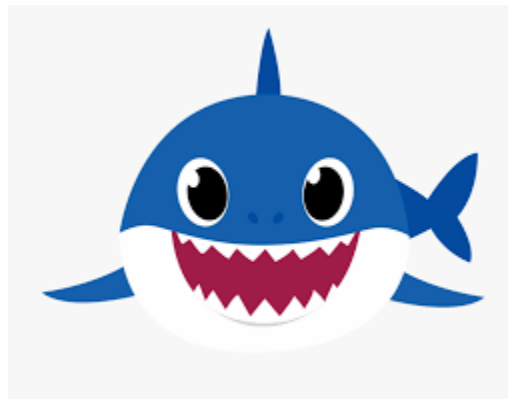



# STRUCTURE

is all about the order sounds happen in

## Key words

**Beginning, middle, ending**

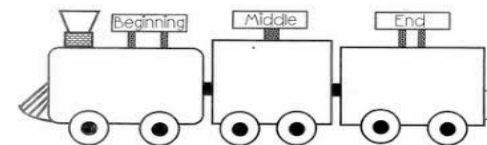

**Call and echo, Call and response**

**Verse, chorus**

**ABA**

[Click here](#)

**to find out about call and echo**

[Click here](#)

**To join in with a call and response song**

**The lady sings the call, join in singing the response with the man**

# Fun structure activities

Listen to [this song](#)

Learn to sing the chorus

*Na na na*

*I'm so happy*

*I'm so happy sing with me*

*x 2*



Count how many times you sing the chorus

What other songs do you know that have a chorus?





# TEXTURE



is all about how many sounds can be heard at the same time

## Key words

Solo

Unison

Layers



[Click here](#)

to watch how layers can slowly be added  
to a piece of music

# Fun texture activity

[Click here](#)

and enjoy adding layers by clicking on the dots to activate 1 2 or 3 sounds at the same time

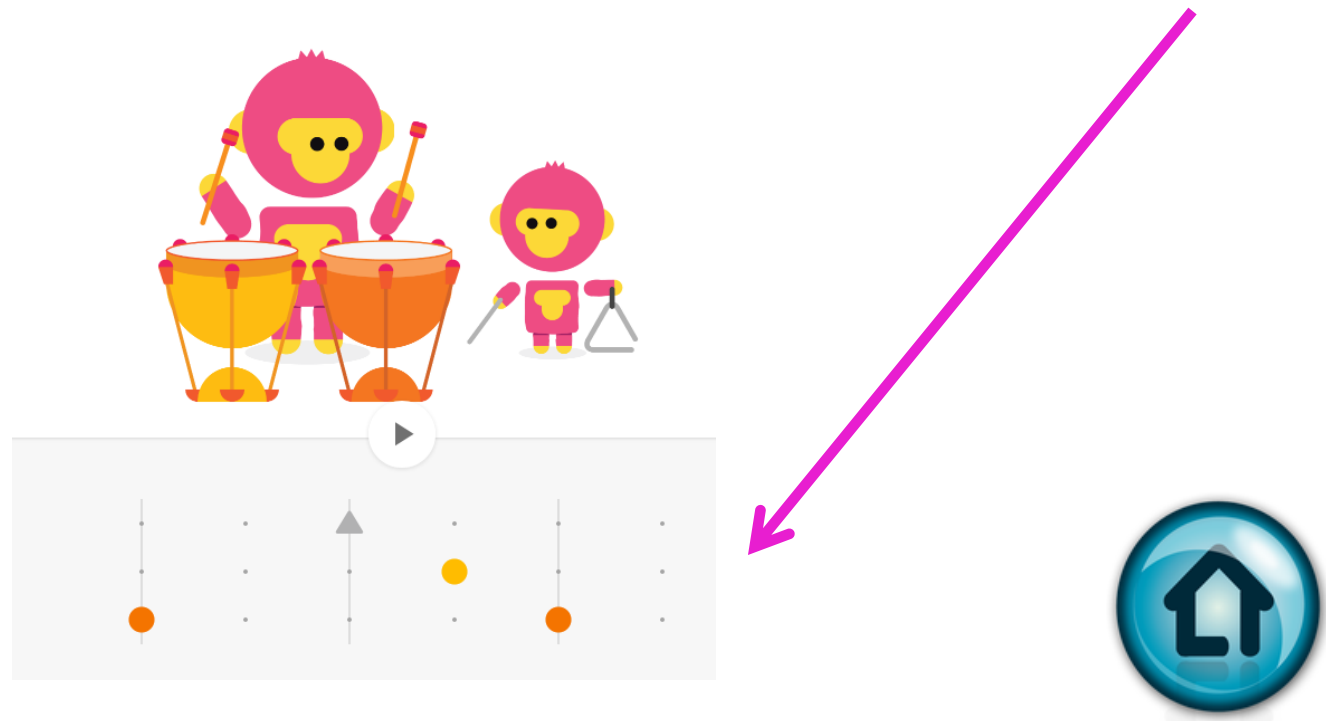

# TIMBRE

is all about what the sounds are like

## Key words

Wood

Metal

Skinned

Shake

Tap

Scrape

Instrument names

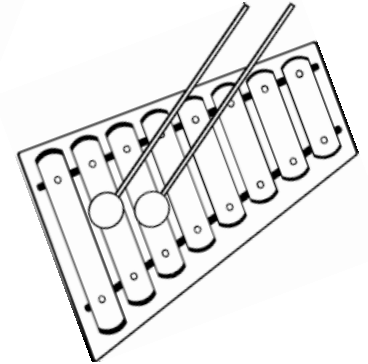
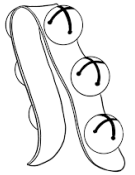
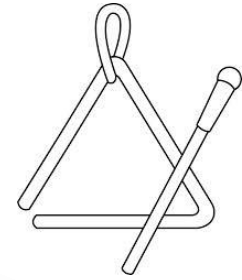

[Click here](#)

to join in with the song and mime playing

Lots of different instruments

# Fun timbre activities



**Go on a treasure hunt for sound makers**

Can you find a wooden sound to play?

Can you find a metal sound to play?

Can you find a skinned sound to play?

Can you find something to tap?

Can you find something to shake?

Can you find something to scrape?

**Draw a treasure chest with all your sound makers around it**



**Make a list of all the wooden, metal and skinned instruments you can think of – which list is the longest?**



# **Name the dimension quiz**

**Look at the slides below**

**Can you work out  
which dimension each is about?**





?

High

Low

Middle

Higher

Lower

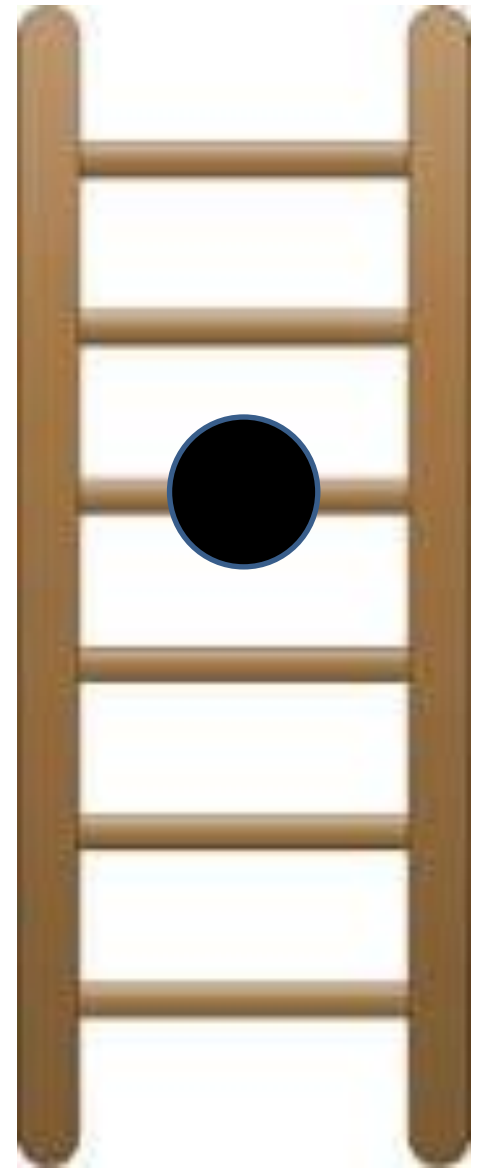

?

Long



Short



Steady beat

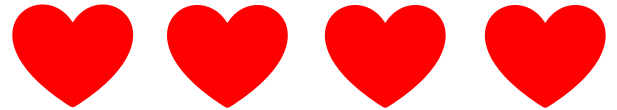

Rhythm pattern

xx xx x x

?

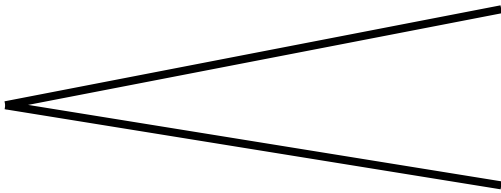
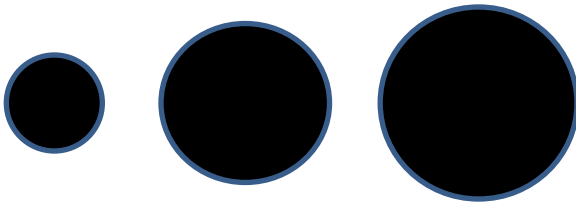

Loud  
Quiet  
Louder  
Quieter

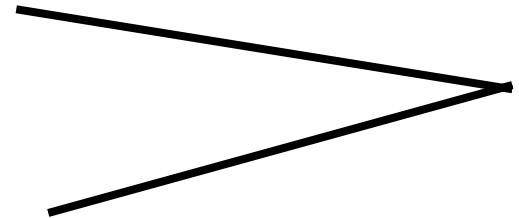
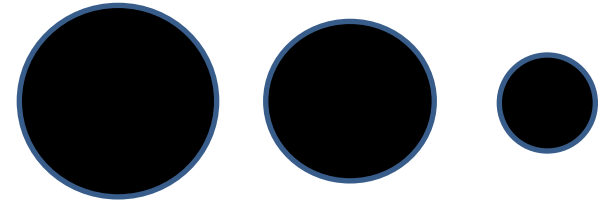

**?**

**Fast**

**Slow**

**Faster**

**Slower**

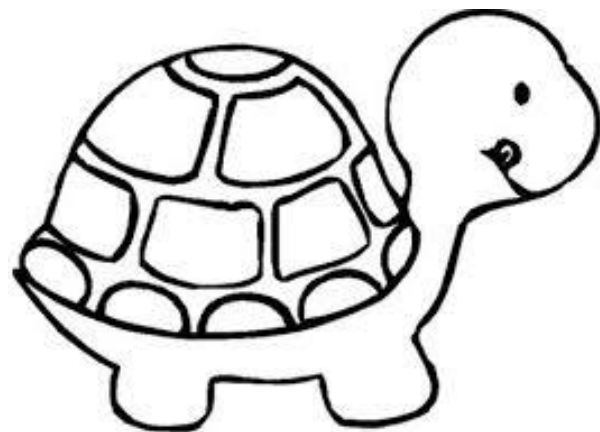



?



**Beginning**

**Ending**

**Beginning, middle, ending**

**Call and echo, Call and response**

**Verse, chorus**

**ABA**

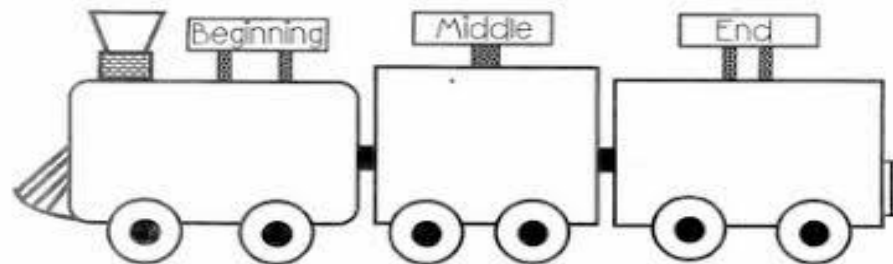

?



**Solo**  
**Unison**  
**Layers**





?

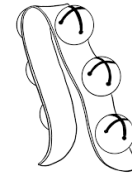
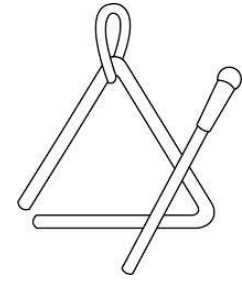

**Wood**  
**Metal**  
**Skinned**  
**Shake**  
**Tap**  
**Scrape**

